

# VIBRATIONAL ANALYSIS OF SUSPENSION SYSTEM FOR ONE- HALF- CAR MODEL WITH FUZZY LOGIC CONTROLLER

Assoc. Prof. Hyniova K., PhD.

Faculty of Information Technology– Czech Technical University in Prague, Czech Republic  
hyniova@fit.cvut.cz

**Abstract:** In the paper, fuzzy logic is used to simulate active suspension control of a one-half-car model. Velocity and acceleration of the front and rear wheels and undercarriage velocity above the wheels are taken as input data of the fuzzy logic controller. Active forces improving vehicle driving, ride comfort and handling properties are considered to be the controller outputs. The controller design is proposed to minimize chassis and wheels deflection when uneven road surfaces, pavement points, etc. are acting on tires of running cars. As a result, a comparison of an active suspension fuzzy control and a spring/damper passive suspension is shown using MATLAB simulations.

**Keywords:** ACTIVE SUSPENSION, FUZZY LOGIC, CONTROL, ONE-HALF-CAR MODEL, SIMULATION, VEHICLE, LINEAR MOTOR, SPRUNG MASS, UNSPRUNG MASS

## 1. Introduction

At the FEE, Czech Technical University in Prague various alternative strategies and innovations to classical passive suspension systems improving ride comfort of the passengers, providing steering stability, maximizing safety and improving handling properties of vehicles has been researched. In order to improve handling and comfort performance instead of a conventional static spring and damper system, an alternative active suspension system has been developed. Certainly, there are numerous variations and different configurations of vibration suspension. In known experimental active systems the force input is usually provided by hydraulic or pneumatic actuators. As an alternative approach to active suspension system design, electromechanical actuators have been studied by the research group. Such actuators provide a direct interface between electronic control and the suspension system. Connection of a passive spring-damper suspension to an active system has a potential of improving safety and comfort under nominal conditions. Perhaps more important is that such a combination allows continuous adaptation to different road surface quality and driving situations.

A number of studies on structural vibration control have been done recently and practical applications have been realized [1]. It is used both, a passive solutions for vibration isolation, and active systems, usually based on PID controllers. In addition, semi-active vibration isolation methods are often proposed and used. Yoshida and Fujio (1999) applied such a method to a base in which the viscous damping coefficient is changed for vibration control. Fukushima *et al.* (1996) developed a semi-active composite-tuned mass damper to reduce the wind and the earthquake induced vibrations on tall structures. Different active control methods of various structures were offered by Nishimura *et al.* (1996). Yagiz (2001) applied sliding mode control for a multi degree of freedom analytical structural system. In the area of semi-active structural control, Zhou and Chang (2000) and Zhou *et al.* (2002) developed a fuzzy controller and an adaptation law for a structure MR damper system. Shurter and Roschke (2001) used a neuro-fuzzy technique to control building models [2]. Liu *et al.* (2001) designed a slightly more intricate fuzzy controller for a MR damper and were able to reduce vibrations of a SDOF bridge model subjected to random inputs.. Simulation of active vibration isolation of a one-quarter-car model with fuzzy logic device has been designed by Nastac in [5]

## 2. Problem Formulation

For the design of active suspension we know how to create a suspension model and how to define objectives of control in order to reach a compromise between contradictory requirements like ride comfort and road holding by changing the force between a wheel and chassis masses. In the past, it has been reported on this problem successively, about the base of optimization techniques, adaptive control and even, H-infinity robust methods [6]. In this paper, fuzzy

logic is used to control the active suspension of a one-half-car model that uses linear electrical motor as an actuator. There are taken velocity and acceleration of the front and rear wheels and undercarriage velocity and vertical acceleration above these wheels as input data of the fuzzy logic controller, and active forces  $f_1$  and  $f_2$  as its output data. The objective of fuzzy control is to minimize chassis and deflections to reach passenger comfort and wheels (not to damage the road surface, respectively) when road disturbances are acting upon the running car.

Passenger comfort can be interpreted as an attenuation of sprung mass acceleration or as peak minimization of sprung mass vertical displacement, while good handling can be characterized as an attenuation of unsprung mass acceleration. This effort devoted to passive suspension design is ineffective because improvements to ride comfort are achieved at the expense of handling and vice versa. Instead, the best result can be achieved by active suspension, i.e. when an additional force can act on the system and simultaneously improve both of these conflicting requirements. Another important goal of the control design is to maintain robustness of the closed loop system.

## 3.Active Suspension System

All suspension systems are designed to meet various specific requirements. In suspension systems, mainly two most important points are supposed to be improved – vibrations absorbing (videlicet passenger comfort) and attenuation of the disturbance transfer to the road (videlicet car handling). The first requirement could be understood as an attenuation of the sprung mass acceleration or as a peak minimization of the sprung mass vertical displacement. The second one is characterized as an attenuation of the force acting on the road or – in simple car models – as an attenuation of the unsprung mass acceleration. The goal is to satisfy both these contradictory requirements.

Satisfactory results can be achieved when an active suspension system generating variable mechanical force acting between the sprung and unsprung masses is used.

Such an actuator can be a linear electric motor [3]. In comparison with traditional actuators that use revolving electromotors and a lead screw or toothed belt, the direct drive linear motor enables contactless transfer of electrical power according to the laws of magnetic induction. The gained electromagnetic force is applied directly without the intervention of mechanical transmission then. Linear electric motors are easily controllable and for features like low friction, high accuracy, high acceleration and velocity, high values of generated forces, high reliability and long lifetime, their usage as shock absorbers seems to be ideal.

Fig.1 shows the basic principle and structure of the linear electric motor used as an actuator in the designed unique active suspension system. The appreciable feature of linear motors is that

they directly translate electrical energy into usable mechanical force and motion and back. They are linear shaped.

Linear motor translator movements reach high velocities (up to approximately 4 m/s), accelerations ( up to g multiples) and forces (up to 10 kN). The electromagnetic force can be applied directly to the payload without an intervention of mechanical transmission.

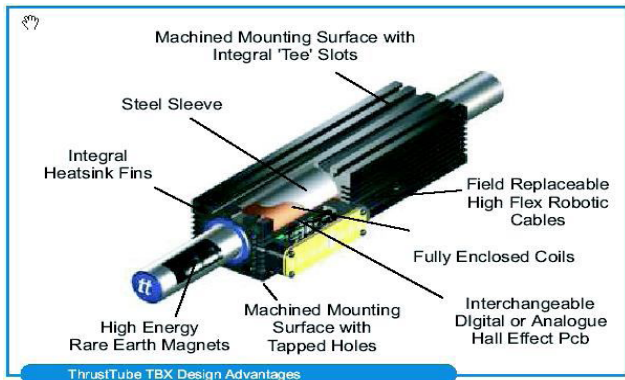

Fig. 1 Linear motor basic design (manufacturer spread sheet).

**4.Linear Motor Model**

In order to verify control algorithms we created a linear motor model including a power amplifier in Matlab/Simulink™. The model enables to demonstrate the conversion of electrical energy to mechanical energy.

In the model, it is assumed that the magnetic field of the secondary part with permanent magnets is sinusoidal, the phases of the primary part coils are star-connected, and a vector control method is used to control the phase current [6]. Here, PWM voltage signal is substituted by its mean value to shorten (about 10 times) the simulation period (inaccuracies caused by such a substitution can be neglected).

The principal inner representation of the model is shown in Fig.2. The model input vector is given by the instantaneous position [m] necessary to compute the commutation current of the coils, instantaneous velocity [m/s] (the induced voltage of the coils depends on the position and velocity) and desired force [N].

The designed model function we verified comparing dynamics of the model (see Fig.3) and the real motor. The simulation parameters correspond to catalogue parameters of TBX3810 linear motor fy Thrust-tube.

For example, time responses caused by changes of the desired force have been compared.

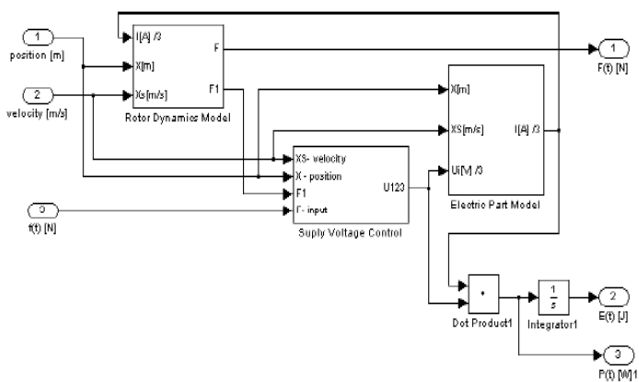

Fig.2. Principal inner model representation.

The linear motor input-output model is shown in Fig. 3

Fig.4 and Fig.5 represent simulated and real time responses, respectively (rightangular force signal: 0→200 [N], power supply of 150 [V], velocity: 0 [m/s]).

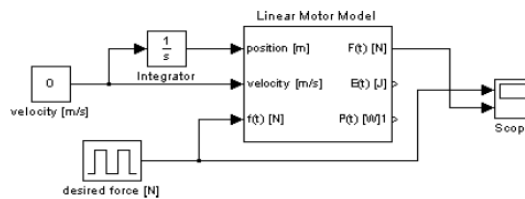

Fig. 3 Linear motor input/output model for dynamics verification.

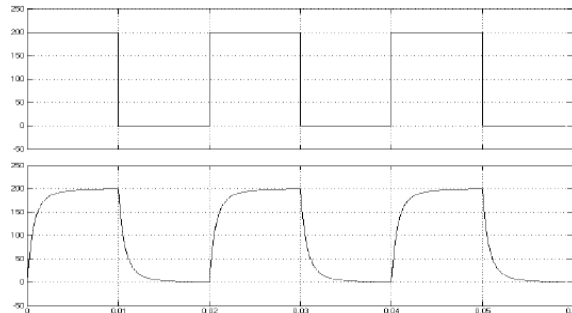

Fig.4 Simulated time response.

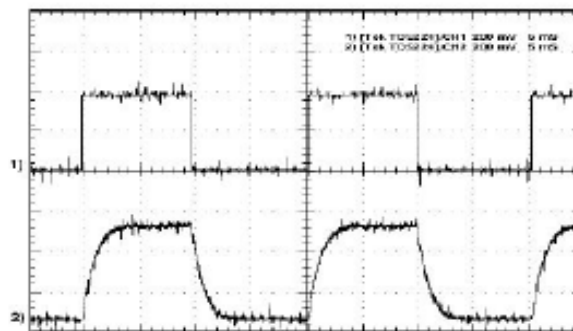

Fig.5 Real time response.

Comparing the time responses in Fig.4 and Fig.5 it can be seen very good matching level of the model and real motor behavior.

On the base of the experiments that we completed on the model, we gained values of electric power necessary to be supplied or consumed when velocity and force of the motor are constant. In Fig. 6 an input/output model of the linear motor (with concrete simulation values) is represented.

It results from many experiments we made [6] with TBX3810 linear motor that the designed model describes the real linear motor equipped with necessary auxiliary circuits very authentically and enables to verify control algorithms developed to control the linear motor as an actuator of the active suspension system.

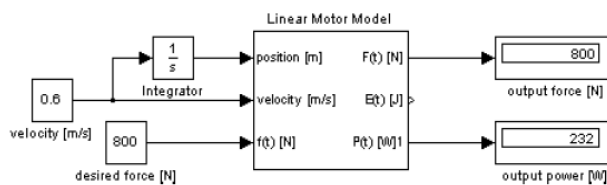

Fig.6 Linear motor input-output model.

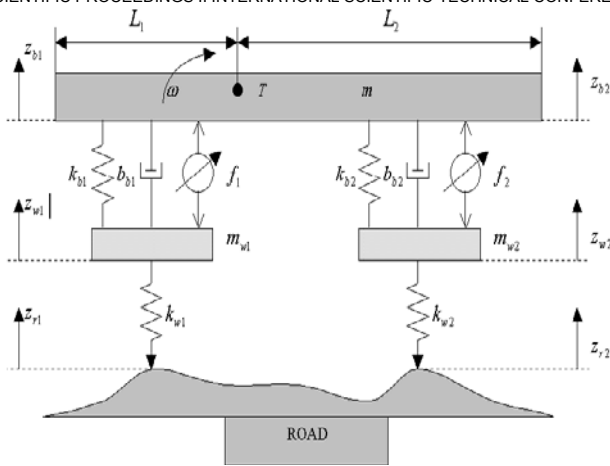

Fig. 7 One-half-car model.

**5. One-half- car Suspension Model**

In this paper, we are considering a one-half-car model in Fig.7 which includes two one-quarter-car models connected to a homogenous undercarriage [6]. The undercarriage is determined by its mass - m [kg] (taken as one half of the total body mass - 500 kg), length L [m] (L = L<sub>1</sub> + L<sub>2</sub> = 1,5m + 2,5m = 4m), center of gravity position - T[m] (given by L<sub>1</sub> and L<sub>2</sub>) and moment of inertia J<sub>p</sub>=2700 kgm<sup>2</sup>.

The motion equations of the car body and the wheels are as follows:

$$\begin{aligned}
 (1) \quad m_{w1} \ddot{z}_{w1} &= -f_1 + k_{b1}(z_{b1} - z_{w1}) - k_{w1}(z_{w1} - z_{r1}) + b_{b1}(\dot{z}_{b1} - \dot{z}_{w1}) \\
 (2) \quad m_{w2} \ddot{z}_{w2} &= -f_2 + k_{b2}(z_{b2} - z_{w2}) - k_{w2}(z_{w2} - z_{r2}) + b_{b2}(\dot{z}_{b2} - \dot{z}_{w2}) \\
 (3) \quad m \ddot{z}_{b1} &= f_1 - k_{b1}(z_{b1} - z_{w1}) - b_{b1}(\dot{z}_{b1} - \dot{z}_{w1}) = F_1 \\
 (4) \quad m \ddot{z}_{b2} &= f_2 - k_{b2}(z_{b2} - z_{w2}) - b_{b2}(\dot{z}_{b2} - \dot{z}_{w2}) = F_2
 \end{aligned}$$

where the position variables respect the static equilibrium position: m<sub>w1</sub>, m<sub>w2</sub> - wheel masses (35 kg each), k<sub>b1</sub>, k<sub>b2</sub> - passive suspension spring stiffness (16 kN/m each), k<sub>w1</sub>, k<sub>w2</sub> - tire stiffness (160 000 N/m each), b<sub>b1</sub>, b<sub>b2</sub> - passive suspension damping coefficients (980 Ns/m each), f<sub>1</sub>, f<sub>2</sub> - active forces between the front/rear sprung and unsprung masses[N], z<sub>r1</sub>, z<sub>r2</sub> ...- road displacements [m], z<sub>b1</sub>, z<sub>b2</sub> - body (chassis) displacements [m], z<sub>w1</sub>, z<sub>w2</sub> - wheel displacements [m].

To model the road input we assume that the vehicle is moving at a constant forward speed. Then the vertical velocity is a white noise process which is approximately true for most of real roadways.

The pitching equation is given as :

$$(5) \quad F_1 L_1 - F_2 L_2 + J_p \dot{\omega} = 0$$

and motion of the gravity center as:

$$(6) \quad F_1 + F_2 - m_p \ddot{v}_r = 0$$

Note, that:

$$(7) \quad v_{b1} = v_T + \omega L_1$$

and

$$(8) \quad v_{b2} = v_T - \omega L_2$$

where the meaning of constants and variables is as follows:

v<sub>T</sub> [ms<sup>-1</sup>] - velocity of the center of gravity, ω [rad s<sup>-1</sup>] - angular velocity, v<sub>b1</sub> [ms<sup>-1</sup>] - undercarriage velocity above the front wheel, v<sub>b2</sub> [ms<sup>-1</sup>] - undercarriage velocity above the rear wheel.

**6. State-space Model**

To transform the motion equations of the one-half-car model to a state space model, the following state variables vector x (9), input variables vector u (10), and the vector of disturbances v (11), are considered:

$$(9) \quad x = [x_1, x_2, x_3, x_4, x_5, x_6, x_7, x_8]^T$$

Where:

$$\begin{aligned}
 x_1 &= z_{b1} - z_{w1} & x_5 &= z_{w2} - z_{r2} \\
 x_2 &= z_{w1} - z_{r1} & x_6 &= \dot{z}_{w2} \\
 x_3 &= \dot{z}_{w1} & x_7 &= v_T \\
 x_4 &= z_{b2} - z_{w2} & x_8 &= \omega
 \end{aligned}$$

$$(10) \quad u = [f_1, f_2]^T$$

$$(11) \quad v = [\dot{z}_{r1}, \dot{z}_{r2}]^T$$

Then the motion equations of the one-half-car model for the active suspension can be written in the state space form as follows:

$$(12) \quad \dot{x} = Ax + Bu + Fv$$

where for the given data A, B and F are stated in [3][5].

Thanks to the negative real parts of all eigen values of matrix A, the model is stable.

**7. Fuzzy Logic Controller**

The fuzzy control system consists of three stages: fuzzification, fuzzy inference and defuzzification [3], [4].

The fuzzification stage converts real-number (crisp) input values into fuzzy values whereas the fuzzy inference machine processes the input data and computes the controller outputs in cope with the rule base and data base. These outputs, which are fuzzy values, are converted into real-numbers by the defuzzification stage.

The fuzzy logic controller used for the active suspension has nine inputs:

$$(13) \quad [v_{b1}, \dot{v}_{b1}, v_{b2}, \dot{v}_{b2}, v_{w1}, v_{w2}, v_T, \dot{v}_T, \omega]^T$$

and two outputs: f<sub>1</sub> and f<sub>2</sub>. All membership functions are of triangular form. Variables ranges are stated experimentally [2] and are given in Tab.1a and Tab.1b below.

Table 1a: Variables ranges

z <sub>r</sub> [cm]	f <sub>1</sub>   <sub>max</sub> [N]	f <sub>2</sub>   <sub>max</sub> [N]	v <sub>r1</sub>   <sub>max</sub> [m.s <sup>-1</sup> ]	$\dot{v}_T$   <sub>max</sub> [m.s <sup>-2</sup> ]	ω [rad.s <sup>-1</sup> ]
5	2876,4	2949,4	0,3	6,6	0,1
10	5752,8	6062,5	0,5	13,5	0,2

Table 2b: Variables ranges

v <sub>b1</sub>   <sub>max</sub> [m.s <sup>-1</sup> ]	$\dot{v}_{b1}$   <sub>max</sub> [m.s <sup>-2</sup> ]	v <sub>w1</sub>   <sub>max</sub> [m.s <sup>-1</sup> ]	v <sub>b2</sub>   <sub>max</sub> [m.s <sup>-1</sup> ]	$\dot{v}_{b2}$   <sub>max</sub> [m.s <sup>-2</sup> ]	v <sub>w2</sub>   <sub>max</sub> [m.s <sup>-1</sup> ]
0,3	6,8	2,4	0,3	6,8	2,2
0,5	13,5	4,8	0,5	13,5	4,9

The rule base used in the active suspension system for one-half-car model is represented by 160 rules [3], [5] with fuzzy terms derived by modeling the designer's knowledge and experience.

There are two types of rules for the one-half-car model. The rules for unsprung masses are corresponding to the rules of the one-quarter-car model [3], [9], [11] and considering: [v<sub>b1</sub>,  $\dot{v}_{b1}$ , v<sub>b2</sub>,  $\dot{v}_{b2}$ , v<sub>w1</sub>, v<sub>w2</sub>] as fuzzy controller inputs, and f<sub>1</sub> and f<sub>2</sub> as controller outputs.

The output of the fuzzy controller is a fuzzy set of control forces. As processes usually require non-fuzzy values of control, a method of defuzzification called "center of gravity method" is used here [3], [4], [6].

**8. Simulation Results**

In this section, the controller was tested in order to compare the results of the designed fuzzy logic control with a traditional passive suspension system. As an example, step responses of the unsprung and front/rear sprung masses are shown in Fig8- Fig.11

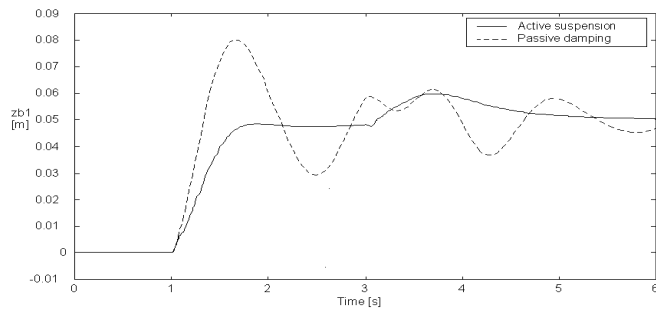

Fig.8 Sprung mass deflection above front wheel

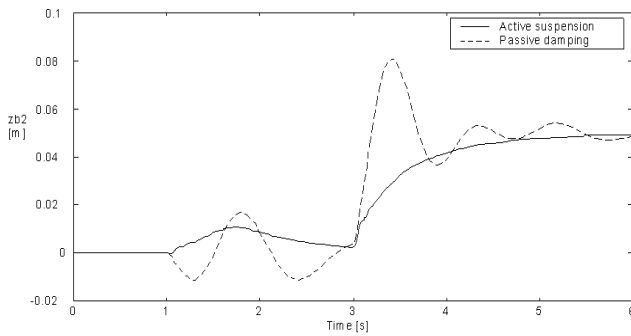

Fig.9 Sprung mass deflection above rear wheel

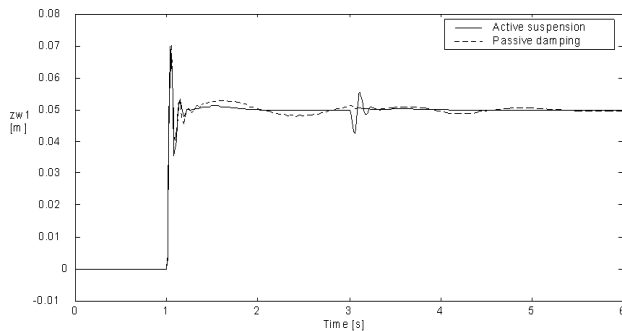

Fig.10 Front unsprung mass (front wheel) deflection

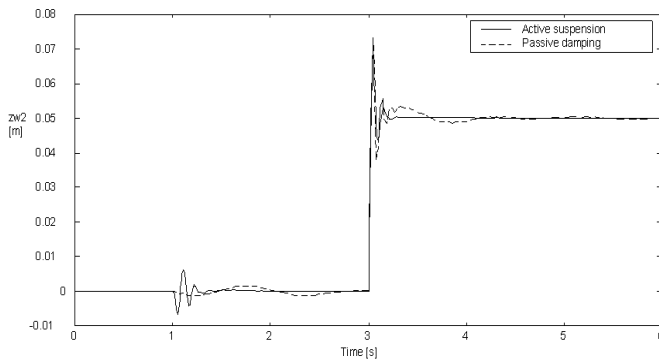

Fig.11 Rear unsprung mass (front wheel) deflection

Analyzing the diagram in Fig.12, it is evident that the classical (passive) suspension device provides almost the same performance as the active suspension system based on the designed fuzzy

machine. Assuming a large complexity of active isolation in comparison with the passive suspension, it seems to be inadequate to use a fuzzy machine for active suspension control.

From Fig.9 and Fig.10, it is evident that fuzzy controlled active suspension efficiently suppresses sprung mass oscillations that occur when only passive suspension was used.

Diagram in Fig. 13 represent active forces acting on front and rear wheels in order to optimize ride comfort and good handling of the vehicle.

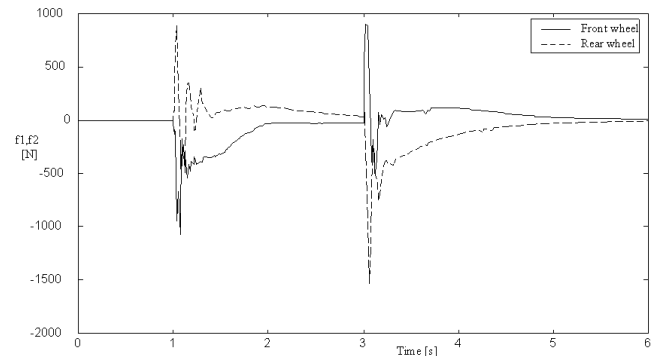

Fig.12 Active forces acting on front/rear wheel.

### 9. Conclusion

In the paper, we briefly described a basic way of fuzzy controlled active suspension system designed for a vehicle one-half-car model.

The entire analysis was developed in Matlab™ - Simulink, with Fuzzy Logic Toolbox. The fuzzy inference machine is also on custody of a special module of Simulink. Practically, the entire process of fuzzification - inference - defuzzification is automaton made by the Fuzzy Logic Controller of Simulink™. The inference machine operation is based on the set of rules which link the input variables by the outputs. The set of input variables, output variables and inference rules base derived by modeling the designers knowledge and experience on vibroisolation devices.

Acknowledgement: This research has been supported by project INGO II LG14005.

### References

- [1] Bratu, P.:Sisteme Elastice de Rezemare Pentru Masini si Utilaje, Ed. Tehnica, Bucuresti, 1990
- [2] Cuclu, R.: Fuzzy Logic Control of Vibration of Analytical Multi-Degree-of- Freedom Structural Systems, Turkish J. Eng. Env. Sci., p157-167, 2003
- [3] Hyniova, K. - Stribrsky, A. - Honcu, J.: Fuzzy Control of Mechanical Vibrating Systems, International Carpatian Control Conference ICC 2001, pp. 393-398, Krytica, Poland, 2001
- [4] Stribrsky, A. - Hyniova, K. - Honcu, J.: Using Fuzzy Logic to Control Active Suspension of Vehicles, Intelligent Systems in Practice, pp.41-49, Luhacovice, 2000
- [5] Nastac, S.: Simulation of active Vibration Isolation with Fuzzy Logic Device, In: Proceedings of the 10<sup>th</sup> international Conference on mathematical and computational methods in Science and Engineering (MACMESE '08), pp. 346-351) Brasov,2008.
- [6] Stribrsky, A. - Hyniova, K. - Honcu, J.: Reduction of Vibrations in Mechanical Systems, Proceedings of Workshop 2001, Part A, pp.174-175, CTU Prague, 2001